

SonicLayer® 7200

UAM Machine

SonicLayer® 7200 Fully Automated System

The SonicLayer® 7200 utilizes the patented 9kW Ultrasonic Additive Manufacturing (UAM) welding head to additively manufacture solid metal parts. The weld head is fed with 1" wide metal foils through an automated feed system that places foils in 3D space to create the desired geometry. The system is also implemented with integrated CNC machining capability. This includes a standard 50-taper 3-axis vertical machining center with a Siemens 840D controller used for achieving

final dimensions at high accuracy. Full machine guarding is included (with a closed top). A water soluble coolant system comes standard with the machine and includes removable screen for chip removal. A secondary alcohol coolant system is also included for use during builds to keep the metal surfaces clean.

The SonicLayer® 7200 is controlled 100% through the use of industry standard G-code programming. The customer has the option to choose the CAD/CAM software. This software creates G-code, which is then transferred to the machine for execution.

Welding Machine

Ultrasonic Power: 9 kW
Welding force: 10,000 lb.
Welding speed (max): 600 ipm
Steel welding sonotrode

Machining Spindle

12,000 rpm CAT 50



Work Envelope

Powered X Axis: 72 in.
Powered Y Axis: 72 in.
Powered Z Axis: 63 in.

Linear Accuracy

Positioning: ± 0.0002 in.
Repeatability: 0.0001 in.

Table Size

Length \times Width: 72 \times 72 in.



HOW IT WORKS: 3D PRINTING WITH SOUND

Ultrasonic Additive Manufacturing (UAM) is a 3D metal printing technology that lets you make the “impossible” parts possible. Fabrisonic has the capabilities to combine dissimilar metals while keeping their metallic properties, embed electronics and sensors without damage, and create complex internal geometry. How does it do that you ask? The process uses ultrasonic sound waves to merge layers of metal foil together in the solid-state; in other words, there is no melting of the metals. The process produces true metallurgical bonds with full density and works with a variety of metals including aluminum, copper, stainless steel, titanium, and more. Dissimilar metals can be printed together due to the low temperature welding process and used for a variety of reasons.

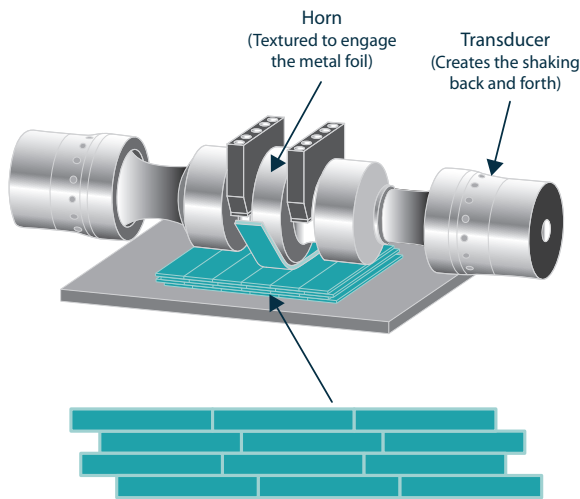

Computer Numerical Control (CNC) machining is used interchangeably with foil layering to introduce internal features along the way and for part finishing. By combining a hybrid system, with both additive and subtractive processes, UAM can build complex internal geometries with smooth finishes considered impossible to replicate with conventional manufacturing. For example, complex chemical reaction chambers with embedded controls and a layer of copper to wick away heat can be easily printed with UAM.

BENEFITS OF UAM

- High-speed process for additive manufacturing of metals
- Large available envelope (6' x 6' x 3') for substantial size parts
- No melting characteristic enables:
 - Bonding of dissimilar metals
 - Cladding
 - Metal matrix composites
 - “Smart” or reactive structures
- Low-temperature process enables:
 - Electronics embedding in tamper-proof structures
 - Non-destructive, fully-encapsulated fiber embedding
- Complex internal geometries
- No post treatments or machining necessary

PRODUCT LINE

SonicLayer® R200 – Research platform for universities and R&D labs

SonicLayer® 4000 – Mid-size fully automated UAM system (40" x 40" x 24")

SonicLayer® 7200 – Production scale automated UAM system (72" x 72" x 36")

To read more about Fabrisonic, go to our website www.fabrisonic.com or visit <http://youtu.be/saSrmgEZJzM> to see our process in action.

