

# SonicLayer® 7200

## UAM Machine

### SonicLayer® 7200 Fully Automated System

The SonicLayer® 7200 utilizes the patented 9kW Ultrasonic Additive Manufacturing (UAM) welding head to additively manufacturer solid metal parts. The weld head is fed with 1" wide metal foils through an automated feed system that places foils in 3D space to create the desired geometry. The system is also implemented with integrated CNC machining capability. This includes a standard 50-taper 3-axis vertical machining center with a Siemens 840D controller used for achieving

final dimensions at high accuracy. Full machine guarding is included (with a closed top). A water soluble coolant system comes standard with the machine and includes removable screen for chip removal. A secondary alcohol coolant system is also included for use during builds to keep the metal surfaces clean.

The SonicLayer® 7200 is controlled 100% using industry standard G-code programming.

The customer has the option to choose the CAD/CAM software. This software creates G-code, which is then transferred to the machine for execution.

#### Welding Machine

Ultrasonic Power: 9 kW  
Welding force: 10,000 lb.  
Welding speed (max): 200 ipm  
Steel welding sonotrode

#### Machining Spindle

12,000 rpm CAT 50



#### Work Envelope

Powered X Axis: 72 in.  
Powered Y Axis: 72 in.  
Powered Z Axis: 36 in.

#### Linear Accuracy

Positioning:  $\pm 0.0002$  in.  
Repeatability: 0.0001 in.

#### Table Size

Length  $\times$  Width: 72  $\times$  72 in.



## HOW IT WORKS: 3D PRINTING WITH SOUND

Ultrasonic Additive Manufacturing (UAM) is a hybrid 3D metal printing technology that enables you to embed electronics and sensors into metal parts of any design. Using only ultrasonic vibrations to bond layers of metal foil together in the solid-state; there is no melting of the metals through the entire process. UAM produces true metallurgical bonds with full density among a variety of metals including aluminum, copper, stainless steel, titanium, and more. Dissimilar metal combinations can be printed together due to the low temperature welding attribute of the process.

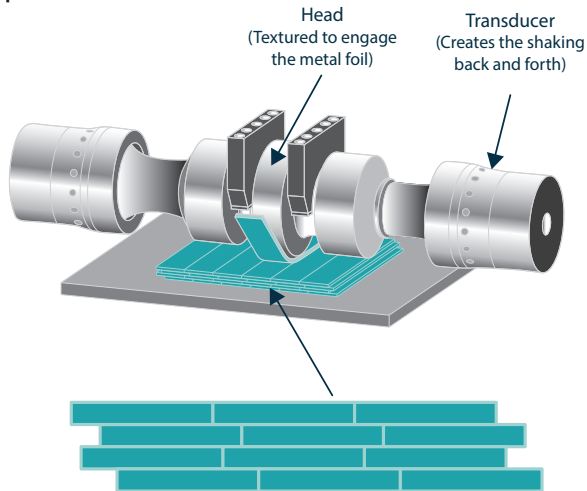

Hybrid metal additive is achieved by alternating Computer Numerical Control (CNC) machining interchangeably with foil layering to introduce precision smooth internal features during the printing process. Working in one machine as a hybrid system, with both additive and subtractive processes, UAM can build complex internal geometries considered impossible to replicate with conventional manufacturing.

## BENEFITS OF UAM

- High-speed process for additive manufacturing of metals
- Large available envelope (6' x 6' x 3') for substantial size parts
- No melting characteristic enables:
  - Bonding of dissimilar metals
  - Cladding
  - Metal matrix composites
  - "Smart" or reactive structures
- Low-temperature process enables:
  - Electronics embedding in tamper-proof structures
  - Non-destructive, fully-encapsulated fiber embedding
- Complex internal geometries
- No post treatments or machining necessary



## PRODUCT LINE

- SonicLayer® R200 – Research platform for universities and R&D labs
- SonicLayer® 1200 – Small format fully automated UAM system (10" x 10" x 10")
- SonicLayer® 4000 – Mid-size fully automated UAM system (40" x 24" x 24")
- SonicLayer® 7200 – Production scale automated UAM system (72" x 72" x 36")

To read more about Fabrisonic, go to our website [www.fabrisonic.com](http://www.fabrisonic.com) or visit <http://youtu.be/saSrmgEZjzM> to see our process in action.